

DIP-GAM

PRELIMINARY

VLA591-01R

DRIVER FOR IGBT MODULES

VLA591-01R

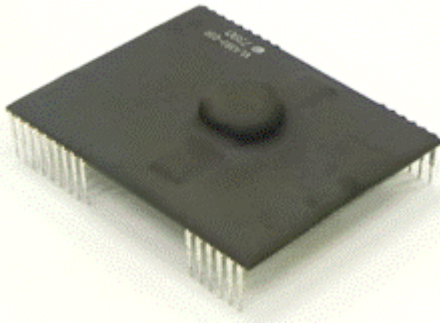

FEATURES

- Low height, DIP structure
- Dual gate drive circuits
- Built in high isolation voltage digital isolators
- Built in isolated DC-DC converter for gate drive
- Built in short circuit protection with soft gate shut down
- Adjustable fall time on activity of short circuit protection
- Output peak gate current is +/-20A(max)
- Isolation voltage is 4000Vrms (for 1 minute)
- CMOS compatible input interface (Input high active type)
- Low voltage lock out for gate power supply(VCC)

TARGETED IGBT MODULES

- V_{CES} = 600V series up to 600A class
- V_{CES} = 1200V series up to 1400A class
- V_{CES} = 1700V series up to 1400A class

APPLICATIONS

To drive IGBT modules for inverter or AC servo system application

BLOCK DIAGRAM

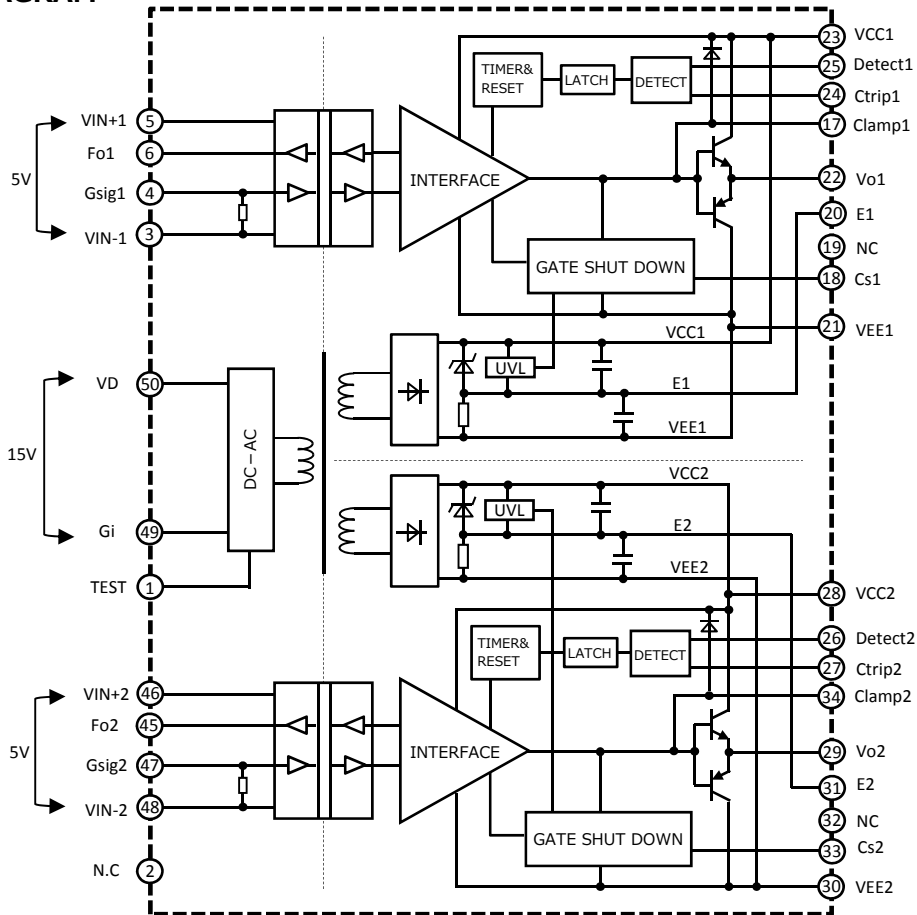

* 1pin: Test pin (Not to be connected electrically to other line)

DIP-GAM

PRELIMINARY

VLA591-01R

DRIVER FOR IGBT MODULES

OUTLINE

Unit : mm

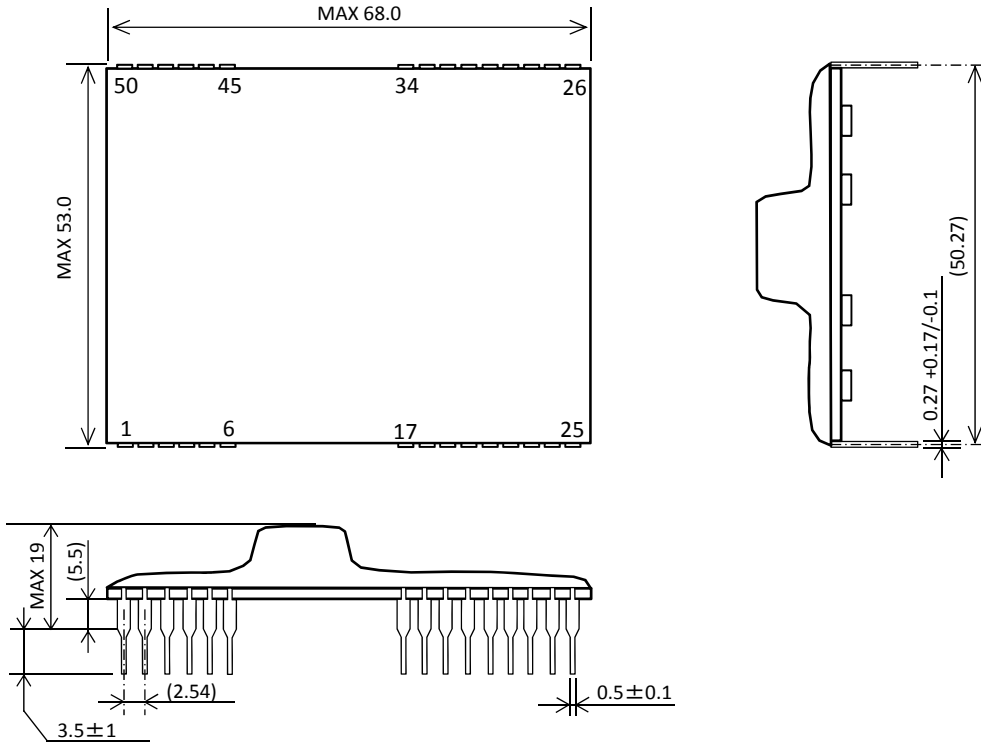

PIN ASSIGNMENT

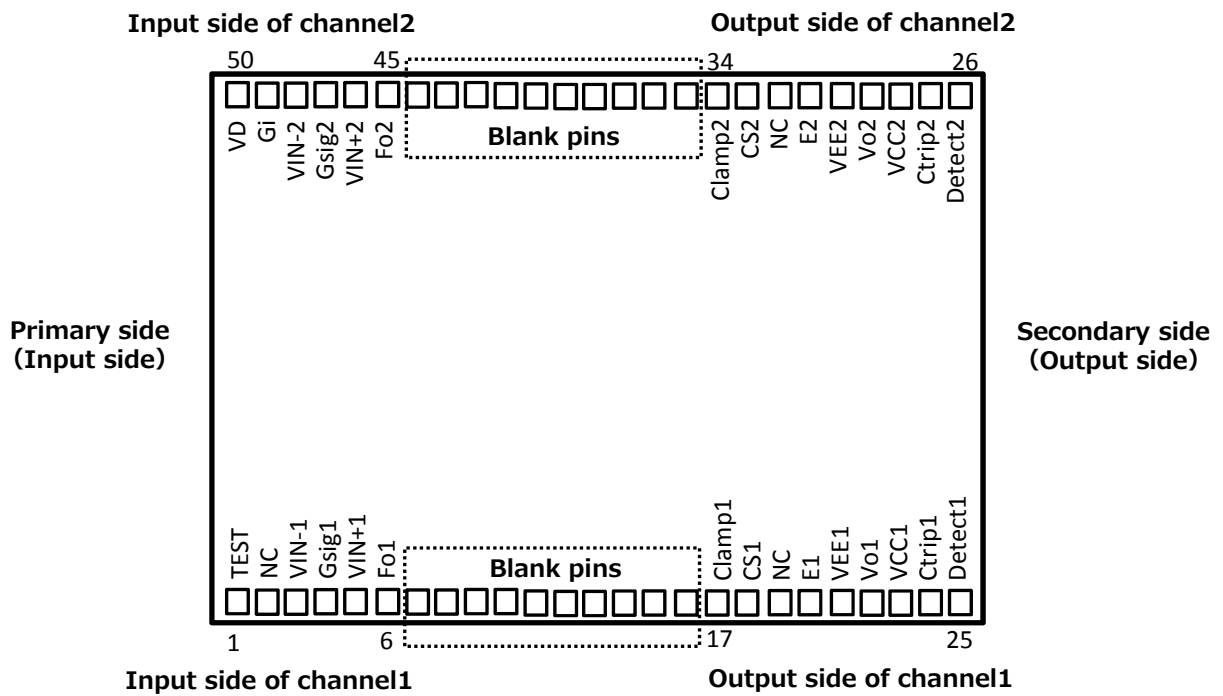

DIP-GAM**PRELIMINARY****VLA591-01R**

DRIVER FOR IGBT MODULES

MAXIMUM RATINGS (Unless otherwise noted, Ta=25 °C)

Symbol	Item	Conditions	Ratings	Unit
VD	Supply voltage	Between VD and Gi	16.5	V
VIN	Supply voltage for gate signal	Between VIN+ and VIN-	6	V
V_Gsig	Gate signal voltage	Between Gsig and VIN-	VIN+0.5 *1	V
IOHP	Output peak current	Pulse width 3us	-20	A
IOLP			20	A
Viso1	Isolation voltage between primary and secondary	Sine wave voltage, 60Hz, 1minute	4000	Vrms
Viso2	Isolation voltage between each output	Sine wave voltage, 60Hz, 1minute	4000	Vrms
Tc	Case temperature	Surface temperature of the exterior resin	100	°C
Topr	Operating temperature	No condensation allowable	TBD	°C
Tstg	Storage temperature	No condensation allowable	-40 ~ 90	°C
IFo	Fault output current	Applied Fo pin	+/-10	mA
VR_Det	Input voltage at Detect pin	Applied Detect pin	80	V
Idrive	Gate drive current	Gate average current (Total of 2 drive circuits) *Keep case temperature less than 100 °C	200	mA

*1 Maximum voltage must not exceed 6V.

ELECTRICAL CHARACTERISTICS (Unless otherwise noted, Ta=25°C, VD=15V, VIN=5V, RG=1.5Ω)

Symbol	Item	Conditions	Limits			Unit
			Min	Typ	Max	
VD	Supply voltage	Recommended range	14.5	15	15.5	V
VIN	Supply voltage for gate signal	Recommended range	4.75	5	5.25	V
V_Gsig	Gate signal voltage	Recommended range	3.5	-	VIN	V
f	Switching frequency	Recommended range Keep total gate average current less than 200mA	-	-	50	kHz
RG	Gate resistance	Recommended range	0.5	-	-	Ω
IFo	Fault output current	Recommended range	-4	-	4	mA
VCC	VCC voltage	-	-	16.4	-	V
VEE	VEE voltage	-	-	-9	-	V
η	Gate supply efficiency	2 circuits total load current between VCC and VEE is 200mA	62	70	-	%
VOH	"H" output voltage	Input "H" (High active)	13.5	15.2	16.5	V
VOL	"L" output voltage	Input "L" (High active)	-6	-8	-11	V
tPLH	"L-H" propagation time	RG=1.5Ω, f=10kHz, C_load:0.33uF	-	TBD	-	us
tr	"L-H" rise time	RG=1.5Ω, f=10kHz, C_load:0.33uF	-	0.52	0.65	us
tPHL	"H-L" propagation time	RG=1.5Ω, f=10kHz, C_load:0.33uF	-	TBD	-	us
tf	"H-L" fall time	RG=1.5Ω, f=10kHz, C_load:0.33uF	-	0.12	0.25	us
ttimer	Timer	Between start and cancel of protection (Under input signal is off state)	1	-	2	ms
VFoL	Fo "L" output voltage	Pull up resistor 4.7kΩ to 5V (1mA sink)	-	0.1	0.2	V
ttrip1	Masked time detect short circuit1	Detect pin:over than15V, Ctrip pin:open	-	TBD	-	us
ttrip2	Masked time detect short circuit2 *2	Detect pin:over than15V, Between Ctrip and E pin:capacitor 47pF	-	TBD	-	us
VSC	SC detect voltage	Collector voltage of IGBT	15	-	-	V
UVLO+_VCC	Under voltage lock out (Operation start)	VCC voltage	-	12.6	-	V
UVLO-_VCC	Under voltage lock out (Operation stop)	VCC voltage	-	11.7	-	V

*2 Length of wiring of capacitor masked time detect short-circuit is within 5cm from E and Ctrip pins coming and going

DIP-GAM

PRELIMINARY

VLA591-01R

DRIVER FOR IGBT MODULES

DEFINITION OF CHARACTERISTICS

SWITCHING OPERATION

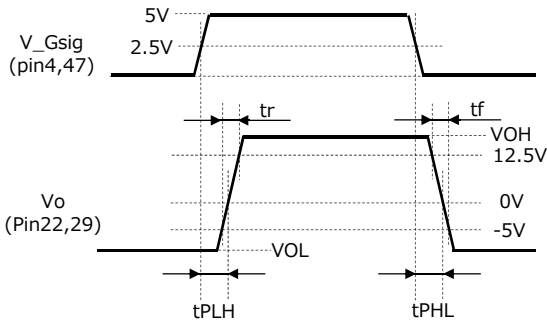

*RG=1.5Ω, C_load:0.33uF, f=10kHz, ON Duty=50%

OPERATION OF SHORT CIRCUIT PROTECTION

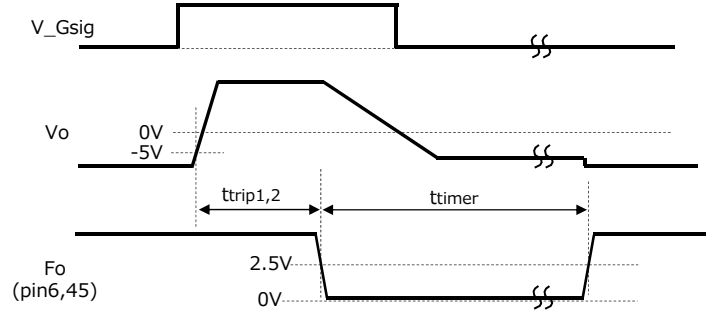

APPLICATION EXAMPLE

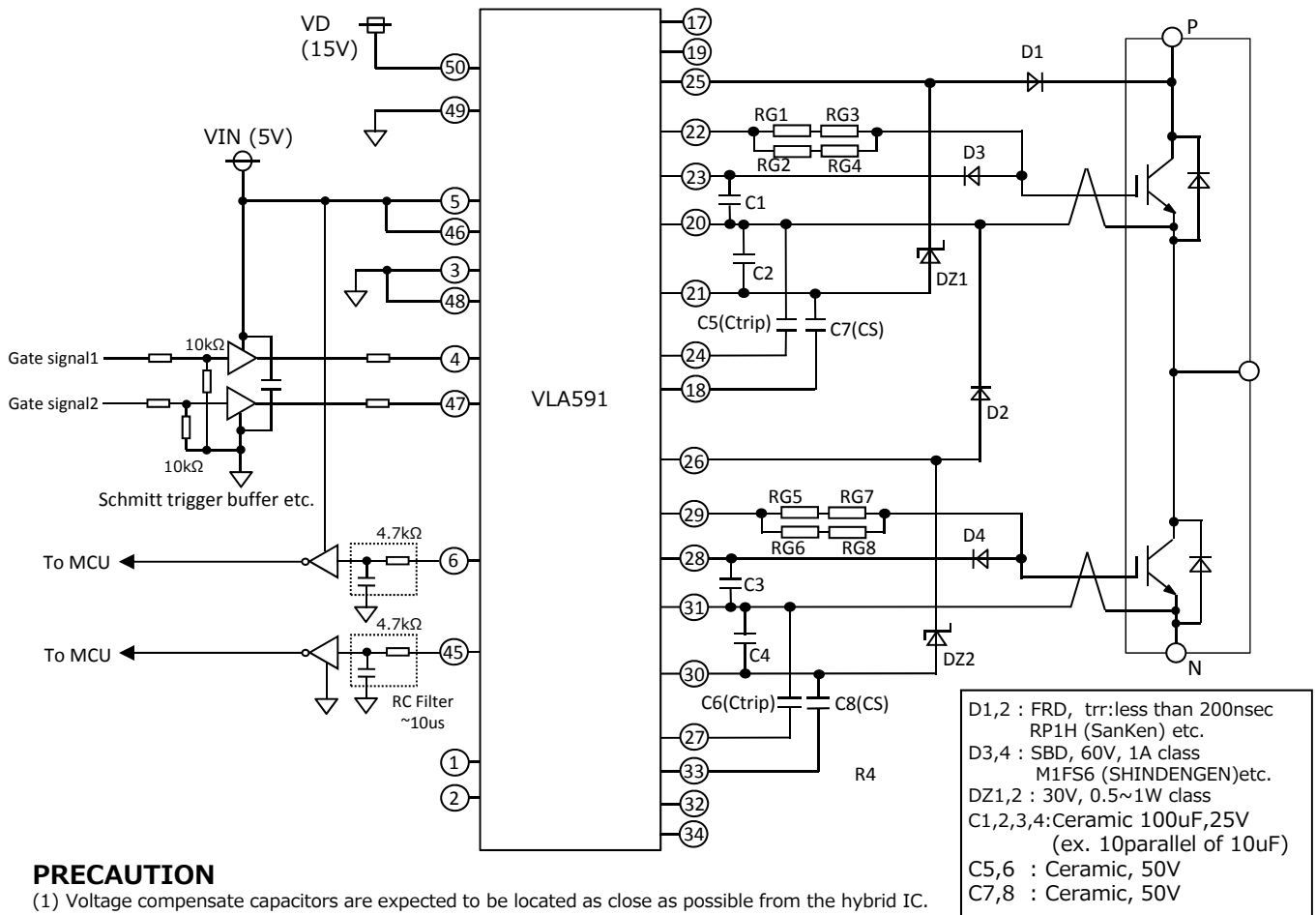

PRECAUTION

- (1) Voltage compensate capacitors are expected to be located as close as possible from the hybrid IC.
- (2) D1,2 require approximately the same voltage of IGBT modules.
- (3) If reverse recovery time of D1 (2) is long, pin25 (26) is applied high voltage. In that case, counterplan for protection which insert zener diode between pin 25 and 21 (pin 26 and 30) is necessary like above diagram.
- (4) In case pin 24 or 27 are operating, the Ctrip is expected to be wired as close as possible from pin. (Less than 5cm coming and going) In case of not using, please keep pin 24 or 27 open.
- (5) Minimize the area of closed circuit of gate circuit and input gate signal circuit so as not to be affected by induction noise.
- (6) When the built in short-circuit protection circuit need not be used, please connect resistance of 4.7k(1/4W) between pin 25 and 20 (pin 26 and 31). At that time, D1 (D2) and Dz1 (DZ2) are not require.
- (7) Pin1 is Test pin. Please not to be connected electrically to other line.
- (8) Please keep pin17 and 34 open ordinarily. These pins are exclusive to our specific product.
- (9) Please keep total gate average current less than maximum rating.
- (10) About the IC which drives gate signal on input side, it is not recommended to use the one whose output is open collector or open drain type.

OPERATION OF PROTECTION CIRCUIT

- (1) In case the gate voltage is "H" and the collector voltage is high, this hybrid IC will recognize the circuit as short circuit and immediately reduce the gate voltage. Besides, put out error signal ("L") which inform that protection circuit is operating at the same time from pin 6 or 45.
- (2) The protection circuit reset and resort to ordinary condition if input signal is "OFF" when the premised 1~2msec passed. ("OFF" period needs 10us or more)
- (3) When the output rises, the masked time detect short circuit (ttrip) is set up so that on-time of IGBT can be secured properly.
It is possible to adjust that time by connecting the capacitor (Ctrip) between pin24 and 20 (27 and 31).
- (4) When the short circuit protection works, the soft gate shut down circuit works to suppress collector surge voltage of IGBT. Furthermore, when it is necessary to be more soft, by adding a capacitor between Cs and VEE terminals, it is possible to make gate shut down speed more slow.

LATCH & TIMER RESET SYSTEM IN SHORT-CIRCUIT PROTECTION CIRCUIT

Once the short-circuit protection circuit starts, it shuts down the gate output and keeps alarm output, causing the latch status. This status is canceled if the input signal is OFF when specific time elapses after the activation of the short-circuit protection circuit. Then, gate output depending on input signals becomes possible. If the input signal is ON when specific time elapses, the latch status is not canceled: it is canceled when the signal becomes OFF.

As mentioned above, on the latch & timer reset system, the latch status is resulted after activation of the protection circuit and shutdown of the gate output. Therefore, during this period, gate output is not made no matter how much input signals are received. For this reason, it is possible to safely stop the entire equipment by sending error signals to the microcomputer during this period to stop all gate signals.

OPERATION FLOW ON DETECTING SHORT CIRCUIT

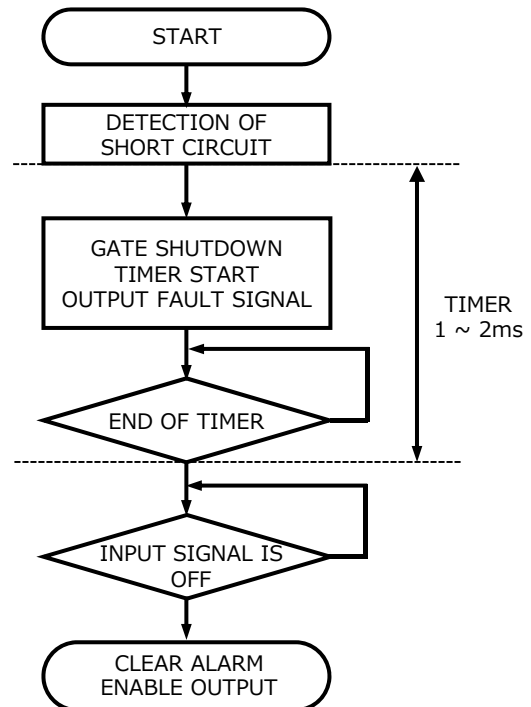

TIMING CHART

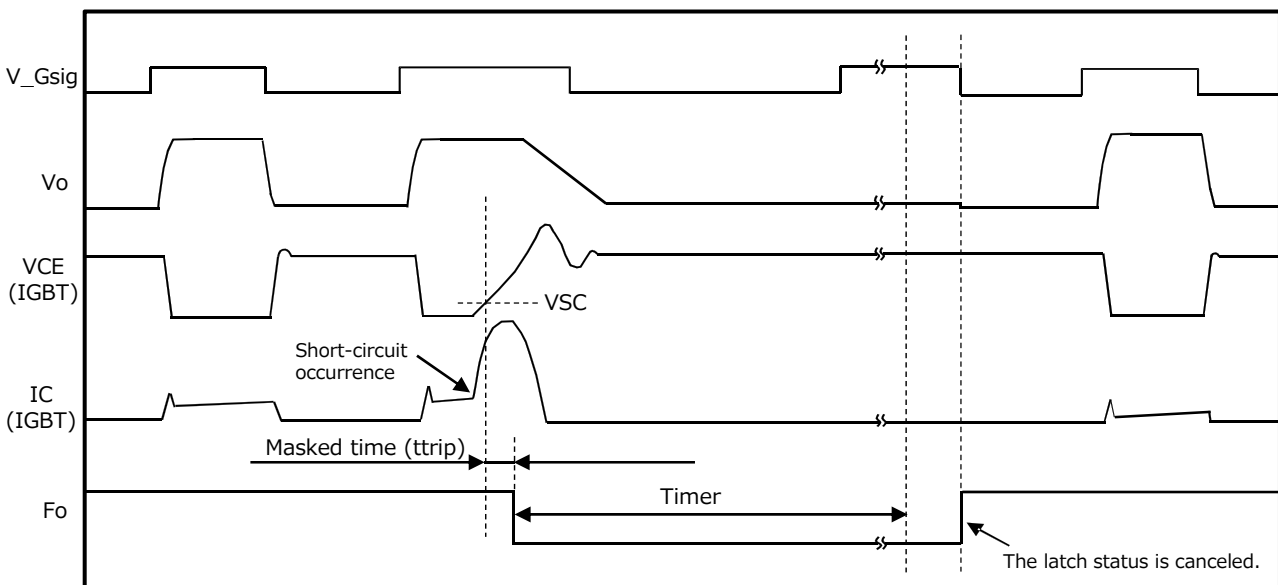

FOR SAFETY USING

Great detail and careful attention are given to the production activity of Hics, such as the development, the quality of production, and in it's reliability. However the reliability of Hics depends not only on their own factors but also in their condition of usage. When handling Hics, please note the following cautions.

CAUTIONS	
Packing	The materials used in packing Hics can only withstand normal external conditions. When exposed to outside shocks, rain and certain environmental contaminators, the packing materials will deteriorates. Please take care in handling.
Carrying	<ol style="list-style-type: none"> 1) Don't stack boxes too high. Avoid placing heavy materials on boxes. 2) Boxes must be positioned correctly during transportation to avoid breakage. 3) Don't throw or drop boxes. 4) Keep boxes dry. Avoid rain or snow. 5) Minimal vibration and shock during transportation is desirable.
Storage	<p>When storing Hics, please observe the following notices or possible deterioration of their electrical characteristics, risk of solder ability, and external damage may occur.</p> <ol style="list-style-type: none"> 1) Devices must be stored where fluctuation of temperature and humidity is minimal, and must not be exposed to direct sunlight. Store at the normal temperature of 5 to 30 degrees Celsius with humidity at 40 to 60%. 2) Avoid locations where corrosive gasses are generated or where much dust accumulates. 3) Storage cases must be static proof. 4) Avoid putting weight on boxes.
Extended storage	When extended storage is necessary, Hics must be kept non-processed. When using Hics which have been stored for more than one year or under severe conditions, be sure to check that the exterior is free from flaw and other damages.
Maximum ratings	To prevent any electrical damages, use Hics within the maximum ratings. The temperature, current, voltage, etc. must not exceed these conditions.
Polarity	To protect Hics from destruction and deterioration due to wrong insertion, make sure of polarity in inserting leads into the board holes, conforming to the external view for the terminal arrangement.

Keep safety first in your circuit designs!

·ISAHAYA Electronics Corporation puts the maximum effort into making semiconductor products better and more reliable, but there is always the possibility that trouble may occur with them. Trouble with semiconductors may lead to personal injury, fire or property damage. Remember to give due consideration to safety when making your circuit designs, with appropriate measures such as (1) placement of substitutive, auxiliary circuits, (2) use of non-flammable material or (3) prevention against any malfunction or mishap.

Notes regarding these materials

·These materials are intended as a reference to our customers in the selection of the ISAHAYA products best suited to the customer's application; they don't convey any license under any intellectual property rights, or any other rights, belonging to ISAHAYA or a third party.

·ISAHAYA Electronics Corporation assumes no responsibility for any damage, or infringement of any third party's rights, originating in the use of any product data, diagrams, charts or circuit application examples contained in these materials.

·All information contained in these materials, including product data, diagrams and charts, represent information on products at the time of publication of these materials, and are subject to change by ISAHAYA Electronics Corporation without notice due to product improvements or other reasons.

It is therefore recommended that customers contact ISAHAYA Electronics Corporation or an authorized ISAHAYA products distributor for the latest product information before purchasing product listed herein.

·ISAHAYA Electronics Corporation products are not designed or manufactured for use in a device or system that is used under circumstances in which human life is potentially at stake. Please contact ISAHAYA Electronics Corporation or an authorized ISAHAYA products distributor when considering the use of a product contained herein for any specific purposes, such as apparatus or systems for transportation, vehicular, medical, aerospace, nuclear, or undersea repeater use.

·The prior written approval of ISAHAYA Electronics Corporation is necessary to reprint or reproduce in whole or in part these materials.

·If these products or technologies are subject to the Japanese export control restrictions, they must be exported under a license from the Japanese government and cannot be imported into a country other than the approved destination.

Any diversion or re-export contrary to the export control laws and regulations of Japan and/or the country of destination is prohibited.

·Please contact ISAHAYA Electronics Corporation or authorized ISAHAYA products distributor for further details on these materials or the products contained therein.