

SPECIFICATION	Prep.	MG	REV	A	03-06-99 : emission		
	Appr.	DLM					

POWER IGBT MODULE SPECIFICATION TENTATIVE

- Type number **CM100TJ-24F**
- Application **General purpose inverter**
- Outline **Sixpack page 3**
- Related Specifications
- Maximum ratings ($T_j = 25^\circ\text{C}$)

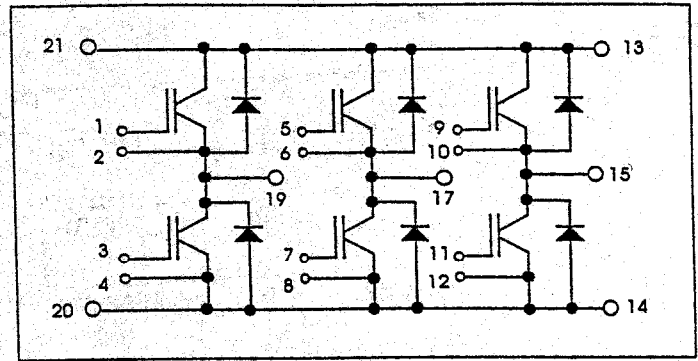

Item	Symbol	Unit	Rating	Conditions
5.1.1 Collector-emitter voltage	V_{CES}	V	1200	G - E Short
5.1.2 Gate-emitter voltage	V_{GES}	V	± 20	C - E Short
5.1.3 Collector current	I_c	A	100	$T_c = 25^\circ\text{C}$
5.1.4 Maximum collector current	I_{CM}	A	200	Pulse ②
5.1.5 Emitter current	$I_{E\text{①}}$	A	100	$T_c = 25^\circ\text{C}$
5.1.6 Maximum emitter current	$I_{EM\text{①}}$	A	200	Pulse ②
5.1.7 Maximum power dissipation	$P_{C\text{③}}$	W	390	$T_c = 25^\circ\text{C}$
5.1.8 Junction temperature	T_j	$^\circ\text{C}$	-40~+150	
5.1.9 Storage temperature	T_{stg}	$^\circ\text{C}$	-40~+125	
5.1.10 Isolation voltage	V_{iso}	V_{rms}	2500	Main terminal to baseplate, A.C. 1 minute

6. Electrical characteristics ($T_j = 25^\circ\text{C}$)

Item	Symbol	Unit	Min.	Typ.	Max.	Conditions
6.1.1 Collector-cutoff current	I_{CES}	mA	-	-	1	$V_{CE} = V_{CES}, V_{GE} = 0V$
6.1.2 Gate-emitter threshold voltage	$V_{GE(th)}$	V	5	6	7	$I_c = 10mA, V_{CE} = 10V$
6.1.3 Gate leakage current	I_{GES}	μA	-	-	20	$V_{GE} = V_{GES}, V_{CE} = 0V$
6.1.4 Collector to emitter saturation voltage	$V_{CE(sat)}$	V	-	1.8	2.4	$T_j = 25^\circ\text{C}$ $I_c = 100A$
			-	1.9	-	$T_j = 125^\circ\text{C}$ $V_{GE} = 15V\text{④}$
6.1.5 Input capacitance	C_{ies}	nF	-	-	39	$V_{CE} = 10V$
6.1.6 Output capacitance	C_{oes}		-	-	1.7	$V_{GE} = 0V$
6.1.7 Reverse transfer capacitance	C_{res}		-	-	1.6	$f = 1\text{MHz}$
6.1.8 Total gate charge	Q_g	nC	-	1100	-	$V_{CC} = 600V, I_c = 100A,$ $V_{GE} = 15V$
6.1.9 Turn-on delay time	$t_{d(on)}$	ns	-	70	-	$V_{CC} = 600V, I_c = 100A$ $V_{GE1} = V_{GE2} = 15V$ $R_G = 3.1\Omega$ Inductive load switching operation $dI_e/dt \geq 3000A/\mu s$
6.1.10 Turn-on rise time	t_r		-	40	-	
6.1.11 Turn-off delay time	$t_{d(off)}$		-	300	-	
6.1.12 Turn-off fall time	t_f		-	200	-	
6.1.13 Reverse recovery time	$t_{rr\text{①}}$	ns	-	-	150	
6.1.14 Reverse recovery charge	$Q_{rr\text{①}}$	μC	-	4.1	-	
6.1.15 Emitter to Collector voltage	$V_{EC\text{①}}$	V	-	2.3	3.2	$I_e = 100A, V_{GE} = 0V$

SPECIFICATION	Prep.	MG	REV	A	03-06-99 : emission		
	Appr.	DLM					

7. Thermal resistances

Item	Symbol	Unit	Min.	Typ.	Max.	Conditions
7.1 Thermal resistance	Rth(j-c) ⑤,⑥	°C/W	-	-	0.32	IGBT part Per 1/6 module
7.2 Thermal resistance	Rth(j-c) ⑤,⑥	°C/W	-	-	0.36	FWD part Per 1/6 module
7.3 Thermal resistance	Rth(c-f) ⑤	°C/W	-	0.13	-	Case to Fin , thermal compound applied (1/6 module)
7.4 Thermal resistance	Rth(j-c') ⑤,⑦	°C/W	-	0.18	-	IGBT part - Per 1/6 module Tc measured just under the chip
7.5 Thermal resistance	Rth(j-c') ⑤,⑦	°C/W	-	0.20	-	FWD part - Per 1/6 module Tc measured just under the chip

8. Mechanical characteristics

Item	Symbol	Unit	Min.	Typ.	Max.	Conditions
8.1 Mounting torque		N.m	2.5	-	3.5	Mounting screw M5
8.2 Weight		g	-	300	-	Typical value

① : I_e , $V_{ec,rr}$, Q_{rr} & dI_e/dt represent characteristics of the anti-parallel, emitter to collector free-wheel diode

② : Pulse width and repetition rate should be such that the device junction temperature (T_j) does not exceed T_{jmax} rating .

③ : Junction temperature (T_j) should not increase beyond 150°C.

④ : Pulse width and repetition rate should be such as to cause negligible temperature rise .

⑤ : Thermal resistance is specified under following conditions :

. heatsink flatness : $-100\mu\text{m} / +100\mu\text{m}$ (recommended $\pm 20\mu\text{m}$) with a surface finish of $12\mu\text{m}$ (Rt) or less.

. Shin-etsu silicone G-746 conductive grease applied uniformly (its thickness is $100\mu\text{m} / 200\mu\text{m}$) between module and fin.

. Mitsubishi application manual mounting recommendations should be applied for :

. torquing order of mounting screws (avoiding one side tightening stress)

. using a torque wrench to tighten mounting screws to the specified torque.

⑥ : T_c measuring points for IGBT 21/19 and 15/14 respectively are shown on page 3.

⑦ : If you use this value, $R_{th}(f-a)$ should be measured just under the chip.

