

TENTATIVE

CM150DUS-12F

Pre.	<i>S. Uchida</i>	Rev.	A	<i>S. Uchida</i>
Apr.	<i>M. Tabata 9-Jan-'02</i>			<i>M. Tabata 7-Aug-'02</i>

HIGH POWER SWITCHING USE

Notice : This is not a final specification. Some parametric limits are subject to change.

CM150DUS-12F

- I_c 150A
- V_{CES} 600V
- Insulated Type
- 2-elements in a pack

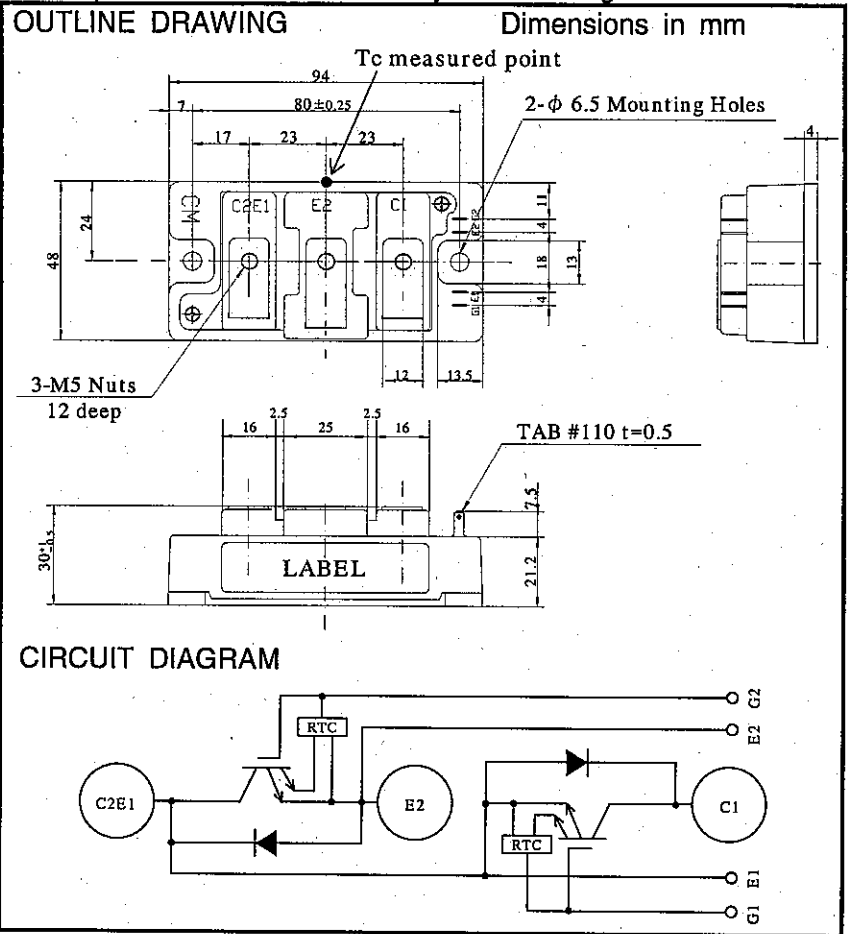

APPLICATION
Welder

ABSOLUTE MAXIMUM RATINGS ($T_j = 25\text{ }^\circ\text{C}$)

Symbol	Item	Conditions	Ratings	Units
V_{CES}	Collector-emitter voltage	G-E Short	600	V
V_{GES}	Gate-emitter voltage	C-E Short	±20	V
I_c	Collector current	$T_c = 25\text{ }^\circ\text{C}$	150	A
I_{CM}		Pulse (2)	300	
I_E (1)	Emitter current	$T_c = 25\text{ }^\circ\text{C}$	150	A
I_{EM} (1)		Pulse (2)	300	
P_c (3)	Maximum collector dissipation	$T_c = 25\text{ }^\circ\text{C}$	520	W
T_j	Junction temperature		-40 ~ +150	$^\circ\text{C}$
T_{stg}	Storage temperature		-40 ~ +125	$^\circ\text{C}$
Viso	Isolation voltage	Main terminal to base plate, AC 1 min.	2500	V
-	Torque strength	Main Terminal M 5	2.5 ~ 3.5	N-m
-		Mounting holes M 6	3.5 ~ 4.5	
-	Weight	Typical value	310	g

ELECTRICAL CHARACTERISTICS ($T_j = 25\text{ }^\circ\text{C}$)

Symbol	Item	Conditions	Min.	Typ.	Max.	Units
I_{CES}	Collector cutoff current	$V_{CE}=V_{CES}, V_{GE}=0V$	-	-	1	mA
$V_{GE(th)}$	Gate-emitter threshold voltage	$I_C=15\text{ mA}, V_{CE}=10V$	5	6	7	V
I_{GES}	Gate leakage current	$V_{GE}=V_{GES}, V_{CE}=0V$	-	-	20	μA
$V_{CE(sat)}$	Collector to emitter saturation voltage	$T_j=25\text{ }^\circ\text{C}$	1.7	2.0	2.7	V
		$T_j=125\text{ }^\circ\text{C}$				
C_{ies}	Input capacitance	$V_{CE}=10V$	-	-	41	nF
C_{oes}	Output capacitance	$V_{GE}=0V$	-	-	2.7	
C_{res}	Reverse transfer capacitance		-	-	1.5	
Q_G	Total gate charge	$V_{CC}=300V, I_C=150A$ $V_{GE}=15V$	-	930	-	nC
$t_{d(on)}$	Turn-on delay time	$V_{CC}=300V, I_C=150A$	-	-	120	ns
t_r	Turn-on rise time	$V_{GE1}=V_{GE2}=15V$	-	-	100	
$t_{d(off)}$	Turn-off delay time	$R_G=4.2\Omega$, Inductive load	-	-	350	
t_f	Turn-off fall time	switching operation	-	-	150	
t_{rr} (1)	Reverse recovery time	$I_E=150\text{ A}$	-	-	150	ns
Q_{rr} (1)	Reverse recovery charge		-	2.8	-	μC
V_{EC} (1)	Emitter-collector voltage	$I_E=150A, V_{GE}=0V$	-	-	2.6	V
$R_{th(j-c)Q}$	Thermal resistance*1	IGBT part(1/2 module)	-	-	0.24	$^\circ\text{C/W}$
$R_{th(j-c)R}$		FWDi part(1/2 module)	-	-	0.47	
$R_{th(c-f)}$	Contact thermal resistance	Case to fin, Thermal compound applied(1/2 module)*2	-	0.07	-	
$R_{th(j-c)Q}$	Thermal resistance	T_c measured point is just under the chips(IGBT part)	-	-	0.19*3	
R_G	External gate resistance		4.2	-	42	Ω

- (1) I_E, V_{EC}, t_{rr} & Q_{rr} represent characteristics of the anti-parallel, emitter to collector free-wheel diode (FWDi).
(2) Pulse width and repetition rate should be such that the device junction temp. (T_j) does not exceed T_{jmax} rating.
(3) Junction temperature (T_j) should not increase beyond 150°C .
(4) Pulse width and repetition rate should be such as to cause negligible temperature rise.

*1: T_c measured point is shown in page "1-2".

*2: Typical value is measured by using Shin-etsu Silicone "G-746".

*3: If you use this value, $R_{th(f-a)}$ should be measured just under the chips.