

# Three-Level IGBT Modules



## Applications

UPS, Solar Inverter, Motor Control

## Features

- Wide range of 3-level IGBT module from 10A to 600A
- Real Time current Controller (RTC) to allow handling of the 3-level specific short circuit turn off routine\*
- Trench gate IGBT (full gate technology) starting from 75A - class
- Pluggable gate and emitter terminals
- 13in1 (with brake), 4in1 and 2 x 2in1 solutions depending on current rating

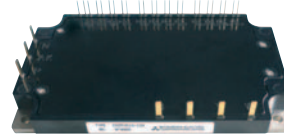

The integrated RTC allows to keep a save turn-off sequence in case of short circuit operation\*

Line-up 75A to 600A ( $V_{CES} = 600V$ )							
Type	$I_c(A)$						
	75	110	165	200	300	400	600
13in1	CM75YE13-12F						
4in1		CM110YE4-12F	CM165YE4-12F	CM200YE4-12F			
2in1					CM300YE2N-12F CM300YE2P-12F	CM400YE2N-12F CM400YE2P-12F	CM600YE2N-12F CM600YE2P-12F

Line-up 10A to 50A ( $V_{CES} = 600V$ )					
Type	$I_c(A)$				
	10	15	25	40	50
13in1	CM10YE13-12H	CM15YE13-12H	CM25YE13-12H	CM40YE13-12H	CM50YE13-12H

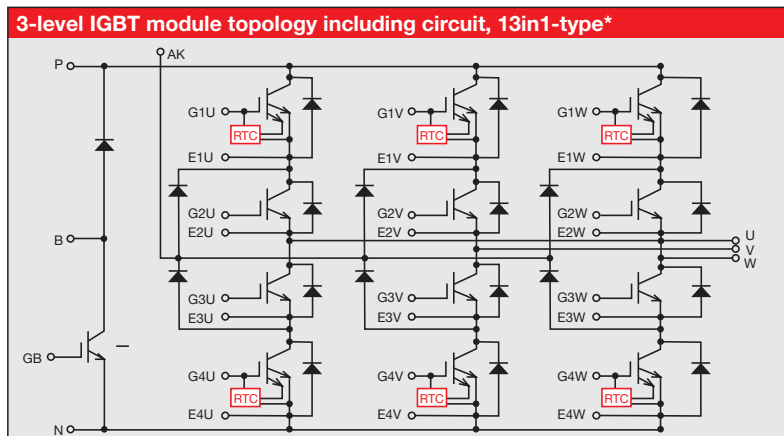

\*RTC implemented for  $\geq 75A$  device rating

