

**Caution:** Verify PCB Orientation Before Applying Power

## BP6A – L-Series IPM Interface Circuit Reference Design

**Description:** The BP6A is a complete isolated interface circuit for high power six pack L-Series IPMs. This circuit provides opto-coupled isolation for control signals and isolated power supplies for the IPM's built-in gate drive and protection circuits. The isolated interface helps to simplify prototype development and minimize design time by allowing direct connection of the IPM to logic level control circuits.

### Features:

- Complete three-phase isolated interface circuit with fault feedback
- 2500VRMS isolation for control power and signals
- Standard AMP MTA .100" Input Signal and Control Power Connectors
- Operates from a single 24VDC supply
- Compact Size 3.2" x 5.5" (80mm x 140mm)

### Applications:

BP6A is designed for use with Powerex L-Series six pack IPMs: 450A-600A 600V and 200A-450A 1200V.

- Use Powerex VLA106-24151 DC to DC converter for isolated control power. See Table 1 for requirements.

**Ordering Information:** **BP6A-L** is a kit containing a bare PCB and six VLA106-24151 DC to DC converters (For use with L-Series IPMs in package D)  
**BP6A** is a bare PCB only.

*Note: User must supply Opto-Couplers and passive components to fully populate the BP6A (See Table 2)*

Table 1: L-Series IPM Line-Up and Interface Circuit Selection

Part Number	Voltage (V)	Current (A)	Package	Recommended DC to DC Converters	Reference Design	
PM50(#L(*)060	600	50	A or B	VLA106-24151 x 4pc.	BP7A	
PM75(#L(*)060		75				
PM100(#L(*)060		100				
PM150(#L(*)060		150	C	VLA106-24151 x 3pc. VLA106-24154 x 1pc.		
PM200(#)LA060		200				
PM300(#)LA060		300				
<b>PM450CLA060</b>		450				
<b>PM600CLA060</b>	600	D	VLA106-24151 x 6pc.	<b>BP6A</b>		
PM25(#L(*)120	1200	25	A or B	VLA106-24151 x 4pc.	BP7A	
PM50(#L(*)120		50				
PM75(#L(*)120		75				
PM100(#)LA120		100	C	VLA106-24151 x 3pc. VLA106-24154 x 1pc.		
PM150(#)LA120		150				
<b>PM200CLA120</b>		200	D	VLA106-24151 x 6pc.		<b>BP6A</b>
<b>PM300CLA120</b>		300				
<b>PM450CLA120</b>	450					

(\*) Package Option: **B**=Solder pin, **A**=Screw terminal

(#) Circuit Option: **R**=Six Pack+Brake, **C**=Six pack

Example:

PM75**RLB**120 is a 75A, 1200V six pack with brake in a solder pin package

**Overview:**

A significant advantage provided by the L-Series IPM's built-in gate drive and protection circuits is that the entire family outlined in Table 1 requires only two different interface circuit designs. The standard interface circuit consists of opto-couplers to transfer control signals and isolated power supplies to power the IPM's internal circuits. The two circuits are similar except that large L-Series IPMs in package D utilize separate control grounds on the low side to minimize ground bounce induced noise. As a result these devices require six isolated power supplies. The Powerex BP6A reference design is an example of this circuit. The remaining devices in packages A, B, and C have a common control ground for all three low side IGBTs. This permits use of a single low side supply so that only four isolated supplies are required. Interface circuit details for these devices are available in the Powerex BP7A reference design application note.

**Isolated DC to DC Converters:**

In order to simplify the design and layout of the required control power supplies, Powerex has introduced the VLA106-24151 isolated DC to DC converter shown in figure 2. The VLA106-24151 operates from a 24V DC supply and produces an isolated 15V DC output at up to 100mA. A Transformer is used to provide 2500VRMS isolation between the primary and secondary side. The BP6A board uses six VLA106-24151 DC to DC converters to supply control power for the L-Series IPM.

Figure 1: L-Series IPMs

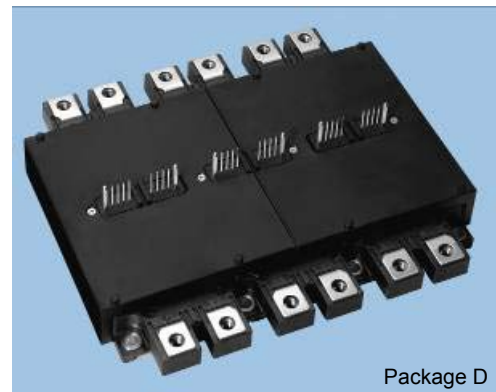
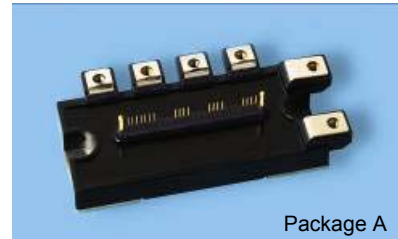

Figure 2: Isolated DC to DC Converter for IPM Control

### BP6A Circuit Explanation:

A complete circuit schematic of the BP6A interface is shown in figure 3 and the bill of materials is given in Table 2. This circuit uses two types of optocoupled transistors to transfer logic level control signals between the system controller and the IPM. The optocouplers provide galvanic isolation to completely separate the controller from the high voltage in the power circuit. The BP6A also provides isolated control power supplies to power the IPM's built-in gate drive and protection circuits.

The six main IGBT on/off control signals ( $U_P, V_P, W_P, U_N, V_N, W_N$ ) are transferred from the system controller to the IPM using high speed optocoupled transistors (IC1-IC6). To maintain noise immunity, high speed optos generally require a film or ceramic decoupling capacitor connected near their  $V_{CC}$  and GND pins (C1-C6). The IPM's active low control inputs are pulled high (off state) by resistors (R1-R6). An on signal is generated by turning on the opto-coupler to pull the IPM's control input pin low. The resistance of the control input pull up resistors is selected low enough to avoid noise pick up by the IPM's high impedance input and high enough so that the high

speed opto-transistor with its relatively low current transfer ratio can still pull the IPM's input low enough to assure turn on. The high speed optocouplers must have very high common mode transient noise immunity. For reliable operation in IGBT power circuits optocouplers with internal shielding and a minimum common mode transient noise immunity of at least  $10,000 \text{ V}/\mu\text{s}$  should be used. The BP6A is designed to use the Agilent HCPL4504 opto-coupler which has a minimum common mode transient noise immunity of  $15,000 \text{ V}/\mu\text{s}$ .

The IPM's fault output signals are transferred back to the system controller using low speed optocoupled transistors (IC7-IC12). During normal operation the fault feedback line (pin 2 of CN1) is pulled high to the  $+V_L$  supply by the 4.7K resistor R15. When a fault condition is detected by the IPM it will immediately turn off the involved IGBT and pull its fault output pin low. The IPM's fault output has an open collector characteristic with an internal 1.5k ohm limiting resistor. Current flows from the  $+15\text{V}$  local supply through the low speed

Figure 3: BP6A L-Series IPM Interface Circuit Schematic

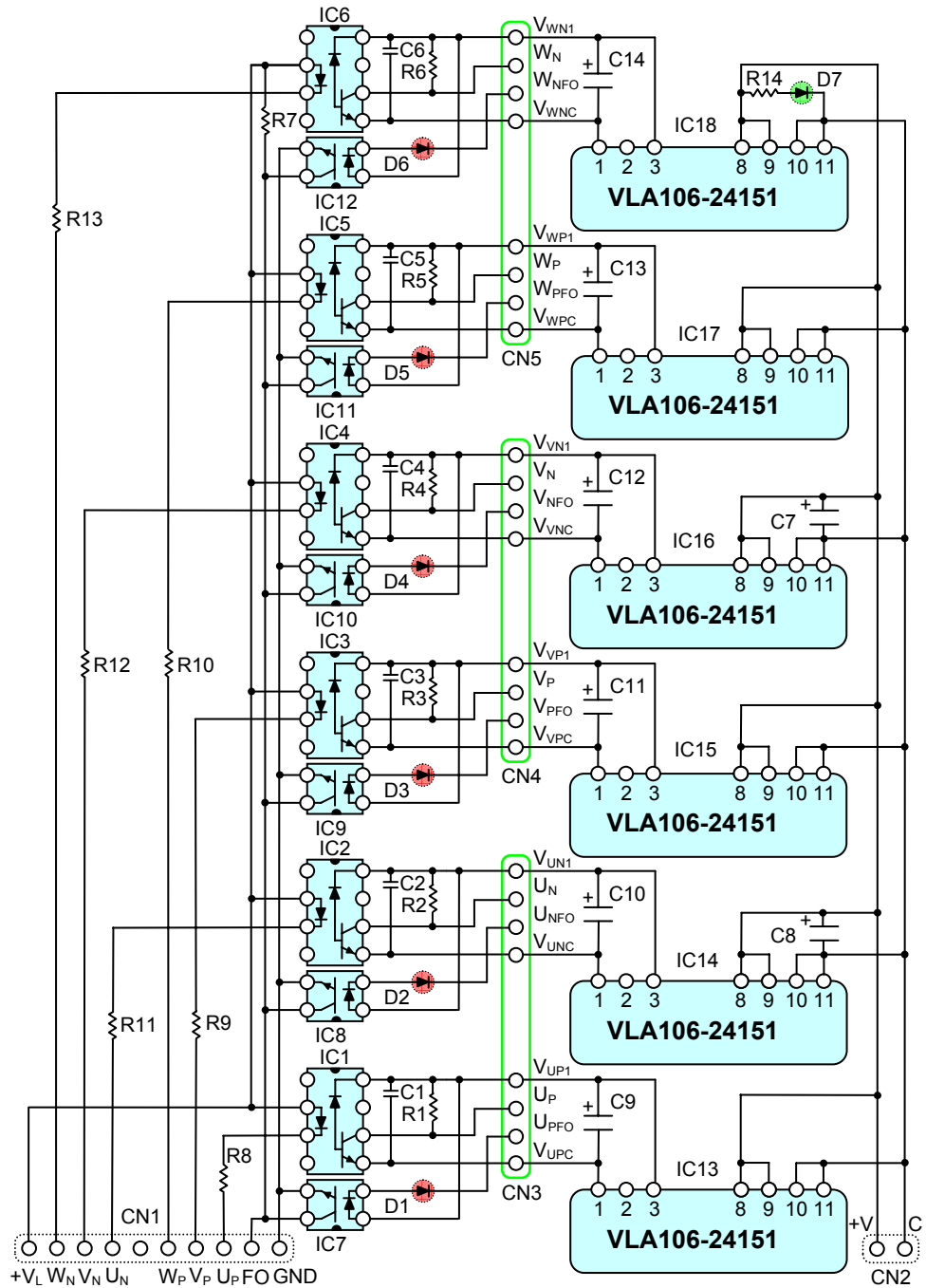
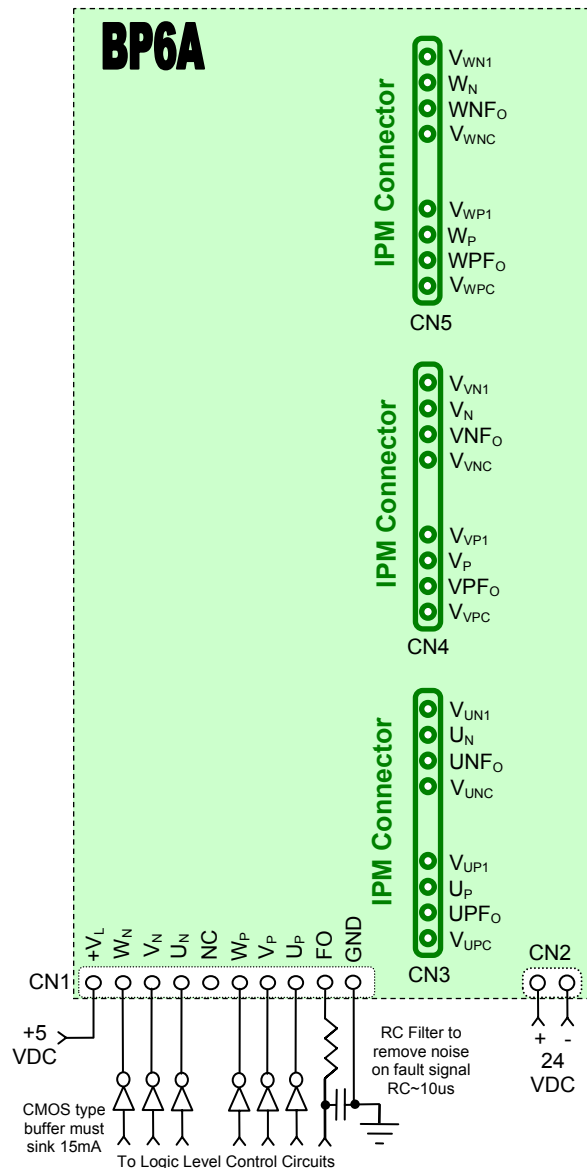

Table 2: BP6A Reference Design Component Selection		
Designation	Characteristic	Description
R1, R2, R3, R4, R5, R6	15K $\Omega$ , 0.25W	Control input pull-up
R8, R9, R10, R11, R12, R13	180 $\Omega$ , 0.25W	Input current limiter (15mA@V <sub>L</sub> =5V)
R7	4.7K $\Omega$ , 0.25W	Fault signal pull-up
R14	1.8K $\Omega$ , 0.25W	Power Indicator Current limiter
C1, C2, C3, C4, C5, C6	0.1 $\mu$ F, 50V Multi-Layer Ceramic	High speed opto decoupling capacitor
C9,C10,C11,C12,C13,C14	39 $\mu$ F, 35V, 105C, Low imp.	Control power decoupling capacitor
C7,C8	560 $\mu$ F, 50V, 105C, Low imp.	DC to DC input decoupling capacitor
D1, D2, D3, D4,D5,D6	Super bright red LED	Fault indicator LED
D7	Super bright green LED	Control power LED
IC1, IC2, IC3, IC4, IC5, IC6	Fast Opto coupler HCPL 4504	Control signal isolator
IC7, IC8, IC9, IC10, IC11,IC12	Slow Opto coupler NEC PS2501	Fault signal isolator
CN1	10 pos. 0.1" right angle single row header	Control signal connector
CN3,CN4,CN5	Single row bottom entry header receptacle	IPM connector Hirose MDF7-11S-2.54DSA(22)
CN2	2 pos. 0.1" right angle single row header	24VDC Control power connector
IC13,IC14,IC15, IC16,IC17,IC18	Isolated DC/DC converter	Powerex P/N VLA106-24151

optocoupler's LED to the IPM's fault pin. The optocoupler's transistor turns on and its collector pulls the fault feedback line low to indicate a fault. If any of the IPM's six fault output signals become active its fault isolation opto will pull the fault feedback line low. Slow optos are used because they offer the advantages of lower cost and higher current transfer ratios. High speed is not necessary because the IPM disables a faulted device and produces a fault signal for a minimum of 1ms. The BP6A also includes an LED in series with each fault output (D1-D6) to provide a quick visual indication when the IPM's fault signal is active. This was included for trouble shooting purposes only so it can be replaced by a jumper without affecting the operation of the interface circuit.

Isolated control power for the IPM is supplied by Powerex isolated DC to DC converters (IC13-IC18) as described above. Each power supply is decoupled at the IPM's pins with a low impedance electrolytic capacitor (C9-C14). These capacitors must be low impedance/high ripple current types because they are required to supply the high current gate drive pulses to the IPM's internal gate driving circuits. The DC to DC converters are powered from a single 24VDC supply connected at CN2. The 24VDC supply is decoupled by the electrolytic capacitors C7 and C8 to maintain a stable well filtered source for the DC to DC converters. The current draw on the 24V supply will range from about 80mA to 380mA depending on the module being driven and switching frequency. For a more accurate estimate it is necessary to use the IPM's circuit current (I<sub>b</sub>) versus f<sub>c</sub> characteristic to obtain the current required by the IPM being used. The IPM current draw can then be adjusted using the DC to DC converter efficiency specification to arrive at the current draw on the 24V supply. Refer to the general IPM application notes for detailed information. A power indicator consisting of an LED (D7) in series with current limiting resistor (R14) is provided to show that the 24VDC supply is present.

Figure 4: BP6A External Connections



---

---

---

---

---

## Controller Interface:

A typical controller interface for the BP6A is shown in figure 4. The control inputs ( $W_N, V_N, U_N, W_P, V_P, U_P$ ) consist of the opto coupler's LED in series with a 180 $\Omega$  current limiting resistor. This combination is designed to provide approximately 16mA of drive current for the optocoupler when a 5V control signal is applied. The anodes of the opto LEDs are tied directly to the 5V logic power supply ( $+V_L$ ). An on signal (IPM control input low) is generated by pulling the respective control input low (GND) using a CMOS buffer capable of sinking at least 16mA (74HC04 or similar). In the off state the buffer should actively pull the control input high to maintain good noise immunity. Open collector drive that allows the control input to float will degrade common mode noise immunity and is therefore not recommended. If a different logic power supply ( $+V_L$ ) voltage is desired the current limiting resistors (R8-R13) must be adjusted. The value of the limiting resistor can be calculated by assuming the forward voltage drop of the optocoupler's photodiode is approximately 1.5V and that the buffer/driver on-state output voltage is approximately 0.6V. For example, if a 15V logic power supply is desired, the required limiting resistors would be:  $(15V - 1.5V - 0.6V) \div 16mA = 800\Omega$ .

If the IPM's built in protection is activated it will immediately shut down the gate drive to the affected IGBT and pull the associated FO pin low. This causes the fault isolation opto to turn on and pull the fault feedback signal (Pin 2 of CN1) low. When a fault is detected by the IPM a fault signal with a minimum duration of 1ms is produced. Any signal on the fault line that is significantly shorter than 1ms can not be a legitimate fault and should be ignored by the controller. Therefore, for a robust noise immune design, it is recommended that an RC filter with a time constant of approximately 10 $\mu$ s be added to the fault feedback as shown in figure 4. An active fault signal indicates that severe conditions have caused the IPM's self protection to operate. The fault feedback signal should be used by the system controller to stop the operation of the circuit until the cause of the fault is identified and corrected. Repetitive fault operations may result in damage to the IPM.

## Printed Circuit Layout:

Figure 5 shows the printed circuit layout of the BG6A interface circuit. The compact 80mm x 140mm circuit board with only 58 components provides a complete isolated six channel driving circuit with short circuit, over temperature and under voltage protection. This clearly demonstrates the advantage of using L-Series Intelligent Power Modules. One important feature of this PCB is the use of separate ground plane islands for each of the isolated driving circuits, logic level interface, and 24V power supply. Six of the islands are tied to the common pin of the IPM's six isolated control power supplies (IPM pins 13, 17, 21, 25, 29, 33). The remaining two islands are connected at the logic ground (pin 1 of CN1) and 24 VDC power supply ground (pin 1 of CN3) respectively. This layout is designed to prevent undesirable coupling of noise between the control side and the floating gate drive channels. The BP6A PCB is designed to plug directly onto the control pins of the L-Series IPM. This configuration helps to maintain good noise immunity by providing minimal interconnection distance.

## More Information:

For more information refer to the following documents available from the Powerex website:

- (1) L-Series IPM individual data sheets provide detailed electrical characteristics of L-Series IPMs
- (2) Application Note – “General Considerations: IGBT & IPM modules”, Provides detailed information on power circuit design including bus bars, snubber circuits and loss calculations. This document also includes heatsink mechanical requirements and proper mounting procedures.
- (3) Application Note – “Introduction to IPMs (Intelligent Power Modules)”, Provides detailed information regarding features, operational characteristics and interface circuit requirements for Intelligent Power Modules.
- (4) BP7A technical data – provides interface circuit information for L-Series IPMs in the low and medium power “A, B, C” packages.
- (5) VLA106-24151 data sheet provides detailed electrical characteristics for the DC to DC converter.
- (6) Melcosim loss simulation software - provides quick power loss estimation for L-Series IPMs in three phase inverter applications.

Figure 5:  
BP6A PCB  
Layout

Component  
Legend

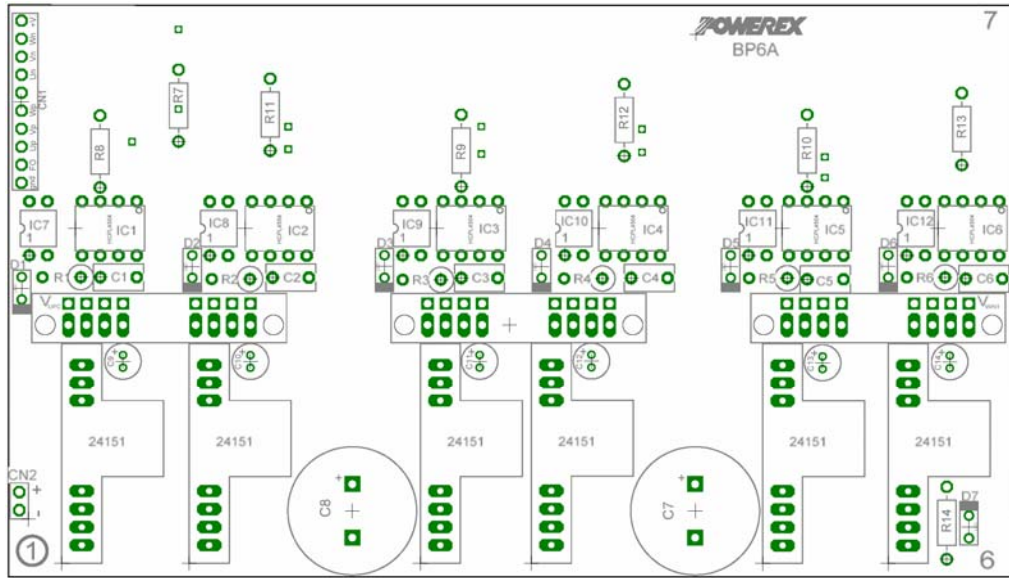

Component  
Side

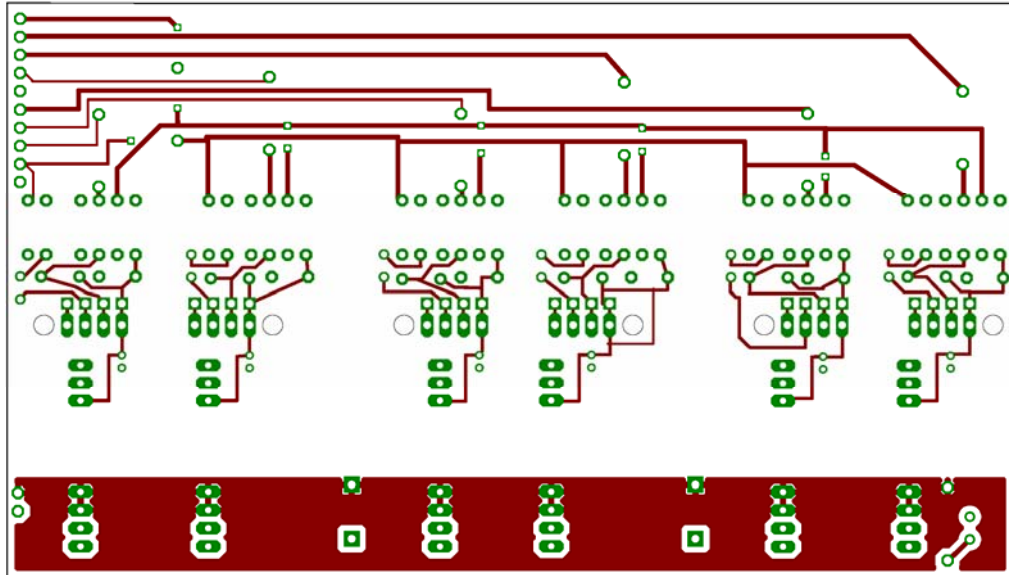

Solder  
Side

