

Dual IGBT Module 600 Amperes/600 Volts

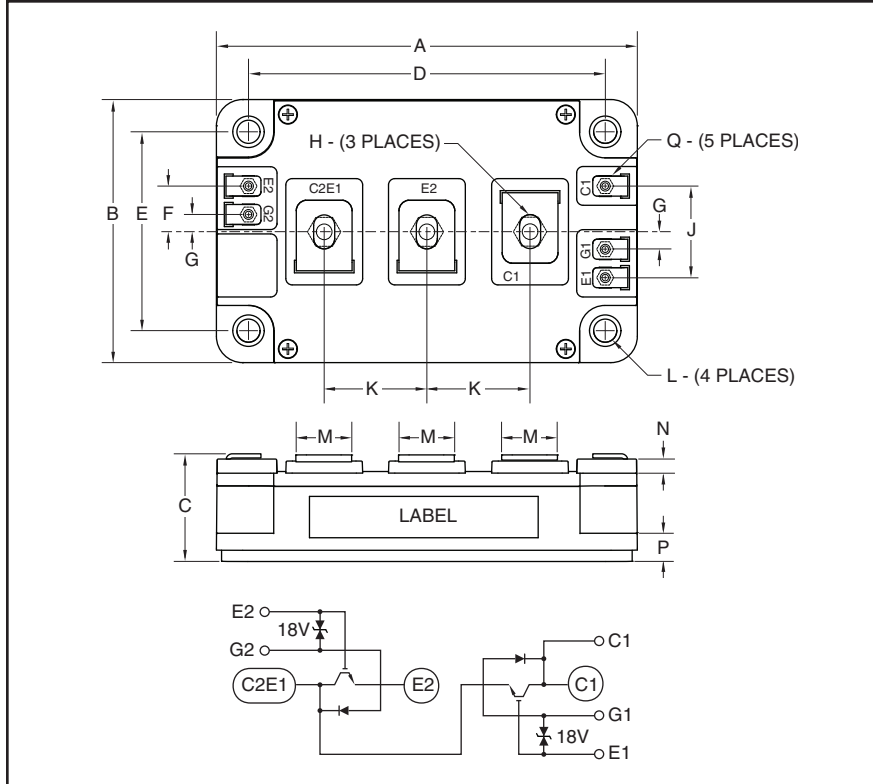

Outline Drawing and Circuit Diagram

Dimensions	Inches	Millimeters
A	4.00	101.6
B	2.50	63.5
C	1.00±0.015	25.4±0.4
D	3.39	86.1
E	1.89	48.0
F	0.435	11.0
G	0.165	4.2
H	#10-32 X 0.31 Min.	

Dimensions	Inches	Millimeters
J	0.87	22.1
K	0.98	24.9
L	0.22 Dia.	5.6 Dia.
M	0.53	13.5
N	0.09 Min.	2.3 Min.
P	0.27	6.9
Q	#2-56 X 0.17 Min.	

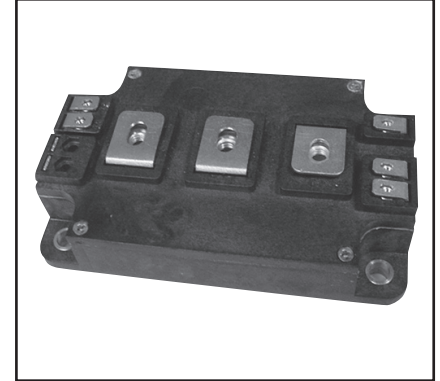

Description:

Powerex Dual IGBT power module is configured as a half-bridge inverter. The Aluminum Silicon Carbide (AlSiC) baseplate offers light weight module design.

The power module is designed to operate reliably in harsh aerospace, military and other environments. The module is rated to operate over full temperature range of -55°C to 125°C.

Powerex is using High Accelerated Stress Test (HAST) to assure long term reliability of plastic power modules.

Features:

- Class H Hybrid Screened to MIL-PRF-38534 Requirements
- Withstand HAST
- Light Weight AlSiC Baseplate
- Low Drive Requirement
- Ultra-fast Free Wheeling Diode
- Internal Zener Protection on Gates
- High Side Collector Sense Pin for De-sat Detection
- High Power Density
- Aluminum Nitride DBC Ceramic

Applications:

- Aerospace
- Military
- Motor Control

QID0660023
Dual IGBT Module
 600 Amperes/600 Volts

Maximum Ratings, $T_j = 25\text{ }^\circ\text{C}$ unless otherwise specified

Ratings	Symbol	QID0660023	Units
Collector Emitter Voltage	V_{CES}	600	Volts
Gate Emitter Voltage	V_{GES}	± 20	Volts
Collector Current	I_C	600	Amperes
Peak Collector Current (1msec)	I_{CM}	1200*	Amperes
Diode Forward Current	I_F	600	Amperes
Diode Forward Surge Current (1msec)	I_{FM}	1200*	Amperes
Junction Temperature	T_j	150	$^\circ\text{C}$
Storage Temperature	T_{stg}	-55 to 125	$^\circ\text{C}$
Mounting Torque, Terminal Screws	—	26	in-lb
Mounting Torque, Control Screws	—	4	in-lb
Mounting Torque, Mounting Screws	—	26	in-lb
Module Weight (Typical)	—	270	Grams
V Isolation	V_{RMS}	2500	Volts

Static Electrical Characteristics, $T_j = 25\text{ }^\circ\text{C}$ unless otherwise specified

Characteristics	Symbol	Test Conditions	Min.	Typ.	Max.	Units
Collector Cutoff Current	I_{CES}	$V_{CE} = V_{CES}, V_{GE} = 0V$	—	—	1.0	mA
Gate Leakage Current	I_{GES}	$V_{GE} = V_{GES}, V_{CE} = 0V$	—	—	10.0	μA
Gate-Emitter Threshold Voltage	$V_{GE(th)}$	$I_C = 60\text{mA}, V_{CE} = 10V$	5.0	6.0	7.5	Volts
Collector-Emitter Saturation Voltage	$V_{CE(sat)}$	$I_C = 600\text{A}, V_{GE} = 15V$	—	1.7	2.2	Volts
		$I_C = 300\text{A}, V_{GE} = 15V$	—	—	2.0	Volts
		$I_C = 600\text{A}, V_{GE} = 15V, T_j = 125^\circ\text{C}$	—	1.7	—	Volts
Total Gate Charge	Q_G	$V_{CC} = 300V, I_C = 600\text{A}, V_{GS} = 15V$	—	2400	—	nC
Diode Forward Voltage	V_{FM}	$I_E = 600\text{A}, V_{GS} = 0V$	—	1.8	2.5	Volts
		$I_E = 600\text{A}, V_{GS} = 0V, T_j = 125^\circ\text{C}$	—	—	2.2	Volts

*Pulse width and repetition rate should be such that device junction temperature (T_j) does not exceed $T_{j(max)}$ rating.

QID0660023
Dual IGBT Module
 600 Amperes/600 Volts

Dynamic Electrical Characteristics, $T_j = 25\text{ }^\circ\text{C}$ unless otherwise specified

Characteristics	Symbol	Test Conditions	Min.	Typ.	Max.	Units
Input Capacitance	C_{ies}		—	—	90	nF
Output Capacitance	C_{oes}	$V_{GE} = 0V, V_{CE} = 10V$	—	—	11.0	nF
Reverse Transfer Capacitance	C_{res}		—	—	3.6	nF
Turn-on Delay Time	$t_{d(on)}$		—	—	500	ns
Rise Time	t_r	$V_{CC} = 300V, I_C = 600A,$	—	—	300	ns
Turn-off Delay Time	$t_{d(off)}$	$V_{GE1} = V_{GE2} = 15V,$	—	—	750	ns
Fall Time	t_f	$R_G = 4.2\Omega, I_E = 600A,$	—	—	300	ns
Diode Reverse Recovery Time	t_{rr}	Inductive Load	—	—	250	ns
Diode Reverse Recovery Charge	Q_{rr}		—	8.7	—	μC
Turn-on Energy	E_{on}	$V_{CC} = 350V, I_C = 300A, R_G = 5.0\Omega,$ $V_{GE} = +15V/-7V, T_j = 125^\circ\text{C}$	—	—	18.0	mJ
Turn-off Energy	E_{off}	$V_{CC} = 350V, I_C = 300A, R_G = 10\Omega,$ $V_{GE} = +15V/-7V, T_j = 125^\circ\text{C}$	—	—	40.0	mJ
Reverse Recovery Energy	E_{rec}	$V_{CC} = 350V, I_C = 300A$ $V_{GE} = -7V, di/dt = -2000A/\mu\text{S}$	—	—	8.0	mJ

Thermal and Mechanical Characteristics, $T_j = 25\text{ }^\circ\text{C}$ unless otherwise specified

Characteristics	Symbol	Test Conditions	Min.	Typ.	Max.	Units
Thermal Resistance, Junction to Case**	$R_{th(j-c)}$	Per IGBT, Half Module, $T_j = 125^\circ\text{C}$	—	0.063	0.075	$^\circ\text{C/W}$
Thermal Resistance, Junction to Case**	$R_{th(j-c)}$	Per FWDi, Half Module, $T_j = 125^\circ\text{C}$	—	0.100	0.120	$^\circ\text{C/W}$
Contact Thermal Resistance, Case to Fin	$R_{th(c-f)}$	Per Module, Thermal Grease Applied	—	0.020	—	$^\circ\text{C/W}$

** T_C measurement point is just under the chip.